

Instruction Manual

BWE 1200

Stationary water softening appliance
with control system RX 79BD / 82BD

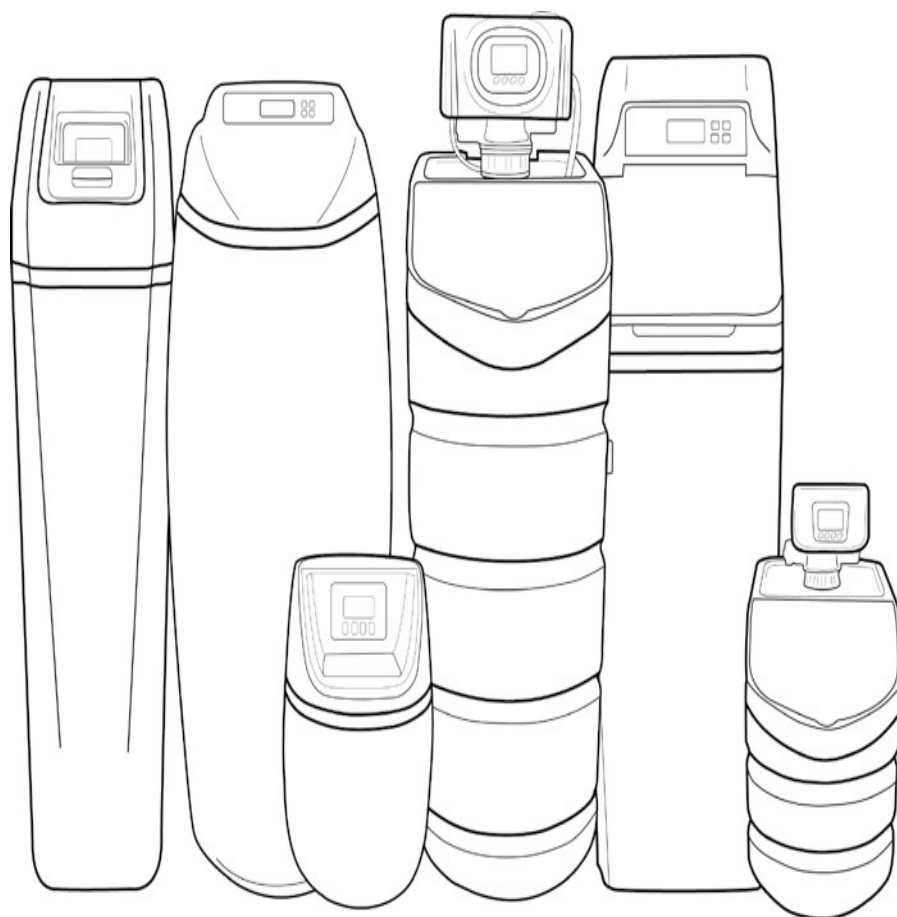

BestWater[®]

Content

- 1. IMPORTANT TERMS OF USE-----4
- 2. How does the water softening device work? -----5
- 3. Delivery Parts List-----5
- 4. Overall View of the water softener appliance -----6
- 5. Preparation for the installation -----7
- 6. Technical data for the water softener appliance -----7
- 7. Water supply connection -----8
 - 7.1 Connecting the appliance to the wastewater outlet-----8
 - 7.2 Connect the brine drain to the wastewater-----8
- 8. Operating mode-----9
- 9. RX Control unit ----- 10
- 10. Description of the control buttons ----- 11
- 11. Fill level control and salt refilling ----- 12
 - 11.1. Initial start-up----- 12
 - 11.2. Checking the Fill level and refilling with salt----- 12
 - 11.3. Prevention of clumping----- 12
- 12. Problem detection----- 13
- 13. Certificate----- 14
- 14. Disposal ----- 14
- 15. TERMS OF WARRANTY ----- 14

Dear customer,

Thank you for deciding to own our BWE 1200 water softening appliance with an RX control system. The functioning of this appliance is based on modern ceramic rotating plate technology and is resistant against deposition of impurities in the water.

The water softener appliance with the RX control system is a good choice to produce recycled water of the highest quality. Please read this instruction manual before operating this appliance in order to avoid damages which could develop through misuse. Particular consideration should be made to the Safety Instructions.

1. IMPORTANT TERMS OF USE

- The improper use of this appliance can lead to permanent damage to the operation or lead to malfunction.
- The water purification system shall be used for its intended purpose. Any disregard of the appliance's operating instructions will negate the guarantee.
- Do not interfere with the design of the softener appliance. Changes to the design will void the warranty.
- The improper use of the softener appliance can lead to damage to your health or even your life.
- Do not touch or handle the electric plug or power cord with wet hands.
- If you detect any damage to the power cord or plug, contact an authorized service centre for this type of repair immediately.
- Do not use a damaged appliance. Once you have detected an error, please contact an Authorized Service Centre.
- It is important that the water treatment system is in a safe place. Avoid contact of water with all electrical components of the water softener.
- Do not clean the softener from the outside with running water.
- Any repairs may only be carried out by trained specialist personnel.
- Protect the appliance against contact with sharp tools and strong impact, do not expose it to high temperatures or fire.
- Secure the location where the device is connected to the power supply.
- The softener should be checked regularly during its operation.
- For proper operation of the system, regular refilling of salt into the brine tank is required; Failure to do so may cause the appliance to malfunction or become damaged.
- Disconnect the device from the power supply when it is to be cleaned or moved. Remember, if the appliance plug is not disconnected, the appliance is live.
- Careless handling of the device while it is connected to the power supply can cause severe paralysis or death.
- Turn off the device before disconnecting it from the power supply.
- The electrical installation to which the device is to be connected must comply with national standards.
- For safety reasons, children and unauthorized persons should not be near the water treatment system.

2. How does the water softening device work?

Hard water containing iron and manganese flows through the main supply line into your home. This water is passed into the water softening appliance which flows through the ion exchanger, which softens the water. The treated water then flows into the water system in your house. An individually programmed softener controls the remaining amount of water for treatment.

After reaching the ion exchange capacity of the ion exchanger, the device is automatically revitalised with prepared saline solution (saline solution in the brine tank). During the revitalisation, the device replenishes the programmed amount of brine in the ion exchanger. This "recharges" the ion exchanger with sodium ions again. The rinsed-out water from the ion exchanger is discharged into the sewage system. During rinsing. During the revitalisation process, the appliance regains its ion exchange capacity and can treat water again. This revitalisation process allows you to use the water treatment system for a long time.

3. Delivery Parts List

Description	amount
Stationary located water softening appliance	1 piece
Bypass	1 piece
12V power supply	1 piece.
2.5-inch spanner for the head collar	1 piece

4. Overall View of the water softener appliance

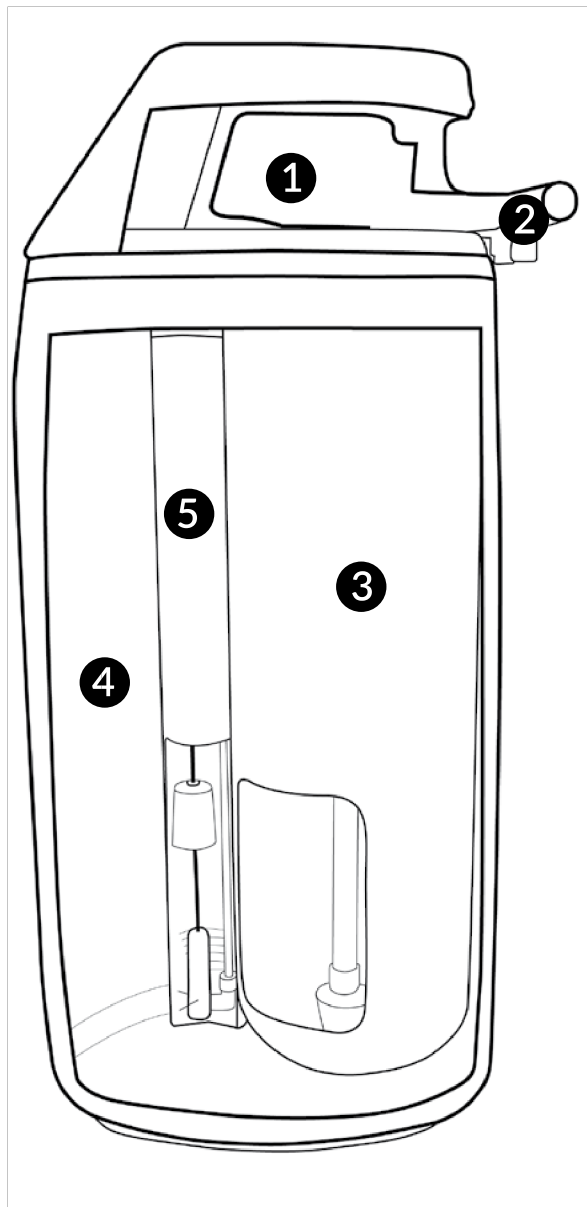

1
The control system is the most important part of the softening appliance. Its functioning technique is based on ceramic plate technology, which is dependent on the relative position to one another, which generate successive work and revitalisation cycles.

The water softener is factory-ready and will work immediately after connection. Only the time of day, the water hardness and the revitalisation time have to be entered.

2
The bypass is another important element that accomplishes several important functions in the operation of the water softening system. Thanks to this bypass, it is possible to quickly and easily remove or add the water softener in to or out of the existing water installation. In addition, you can adjust the water flow in the system, so that softened water or normal tap water flows through. The bypass can also handle mixing functions.

3
The tank is filled with a filter which allows ion exchange. For optimal operation of the device, the filter should be replaced at least every 10 years (depending on the water quality and water hardness).

4

The body of the appliance is made of durable, flexible plastic. It acts as a salt and brine tank. Inside there is mounted a cylinder with a filter, an ion exchanger and a float valve. Check and control the level of the brine in the tank - Protect the unit from overfilling. There is an overflow pipe on the side wall of the housing.

5

The float valve regulates the refilling process of water and supplies the saline solution. Proper functioning ensures the correctness of the revitalisation process.

5. Preparation for the installation

After unpacking the unit, remove the power supply and the bypass valve from the brine tank. When lifting and moving the device, use only the provided recesses in the housing. Do not lift the appliance when it is connected to power or water pipes, as these may then be damaged or torn off. The appliance should be placed as close as possible to the mains water supply pipe of the building (at the water meter for a public water supply) or hydrophore (with own water supply) and near access to the sewage system. In addition, a constant power supply is required to operate the device. Make sure the floor is stable and can support the weight of the water-filled appliance. The selected location should be chosen so that there is free access for the maintenance of the appliance.

6. Technical data for the water softener appliance

The specifications of the water treatment system depend on its size. Because of the small size of the ion exchanger, the system should only be used if water does not receive more than 1ppm of iron and manganese.

Information [Unit]	Parameter value/Information		
Resin volume [L]	20	23	25
Cylinder size [inches]	8 x 35	9 x 35	10 x 35
Nominal flow rate [m ³ / h]	1,2	1,4	1,5
Input connection [m ³ / h]	3/4" for model 79BD 1" for model 82BD		
Output connection [m ³ / h]	3/4" for model 79BD 1" für for model 82BD		
Wastewater connection	1/2		
Brine connection	3/8		
Power [W]	18		
Salt consumption [kg]	2,4	2,7	3,0
Water after the revitalisation	<150	<160	<170
Initiate revitalisation	Manual / automatic / volumetric / automatic after a set time without flow		
Ion exchange capacity	30g CaCO ₃ / L		
Removal of iron and manganese	95% at a concentration of <1 ppm		
Ammonia removal	980 g NH ₄ ⁺ / L		
Size [mm]	460x240x1080	490x300x1055	530x480x1115
Weight [kg]	29	32	34
External Bypass	+	+	+
Built in water softener	+	+	+
Connection possibility for Chlorine generator **	+	+	+

* Reference weight without water and salt ** only in D version of the head-closed menu

7. Water supply connection

ONLY BY AUTHORIZED PERSONS

The appliance should be connected to the existing water supply with flexible hoses (not included). A mechanical filter (at least 50 microns) must be installed. This pre-filter is installed to protect against contamination of the water installation supply and sanitary facilities, such as: rust, sand particles, mud, fibres, etc. It is recommended to install a mechanical filter in front of the water treatment appliance as this will extend its life and ensure a properly functioning appliance.

Locate the water inlet and outlet on the control head (marked with arrows pointing into or out of the device). At the output of the device (in the bypass) is a turbine. Make sure that the turbine is free and rotatable before installation. Use only the specified water installation materials when mounting the unit.

7.1 Connecting the appliance to the wastewater outlet

The flexible wastewater hose must be connected to the wastewater drain and secured with a ½ inch hose clamp. The hose should be positioned below the device head and not be bent at any point. Secure the hose so that it cannot flood the room.

7.2 Connect the brine drain to the wastewater

If the brine inlet and tank filling system is not working properly, the tank may overflow. In this case, the overflow pipe serves as drain for the excess brine. In order to avoid flooding the room in the event of a malfunction, the overflow pipe should be connected to the wastewater drain with a flexible hose.

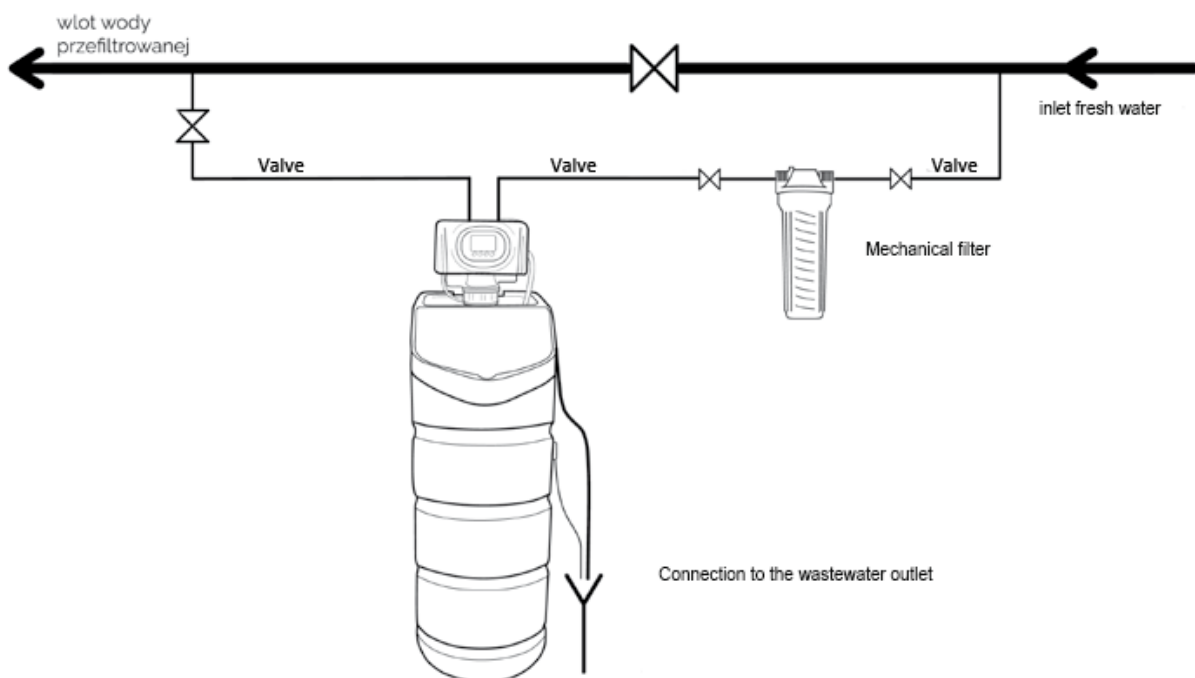

8. Operating mode

During operation, the name of the current operating mode is shown on the display.

During revitalisation, the time remaining until the end of the mode is visible. During the revitalisation, it is possible that fresh water is supplied.

The display shows the following information:

1. the amount of water remaining for revitalisation
2. Current water flow rate
3. Current operating mode

<p>During operation</p>	<p>The appliance is in water treatment mode. Raw water flows through the tank and filter and is routed through the distribution line up to the controller and from there into the house installation system.</p>
<p>Backwash</p>	<p>The unit is in backwash mode. Fresh water flows through the controller to the tank with the ion exchanger and is discharged into the wastewater system. The water rinses the tank and dissolves incrustations.</p>
<p>Refilling the brine and slowly rinsing</p>	<p>Water flows through the control head and causes the brine to be drawn in, which cleans the ion exchanger. Water is then drained into the wastewater during revitalisation. After all the brine has been drawn in, the ion exchange bed is slowly rinsed with water.</p>
<p>Quick Rinse</p>	<p>Provides a quick rinse of the brine residues on the ion exchanger. This improves the correct functioning of the ion exchanger. The water is drawn in from above and directed through the ion exchange resin and then discharged through the central tube.</p>

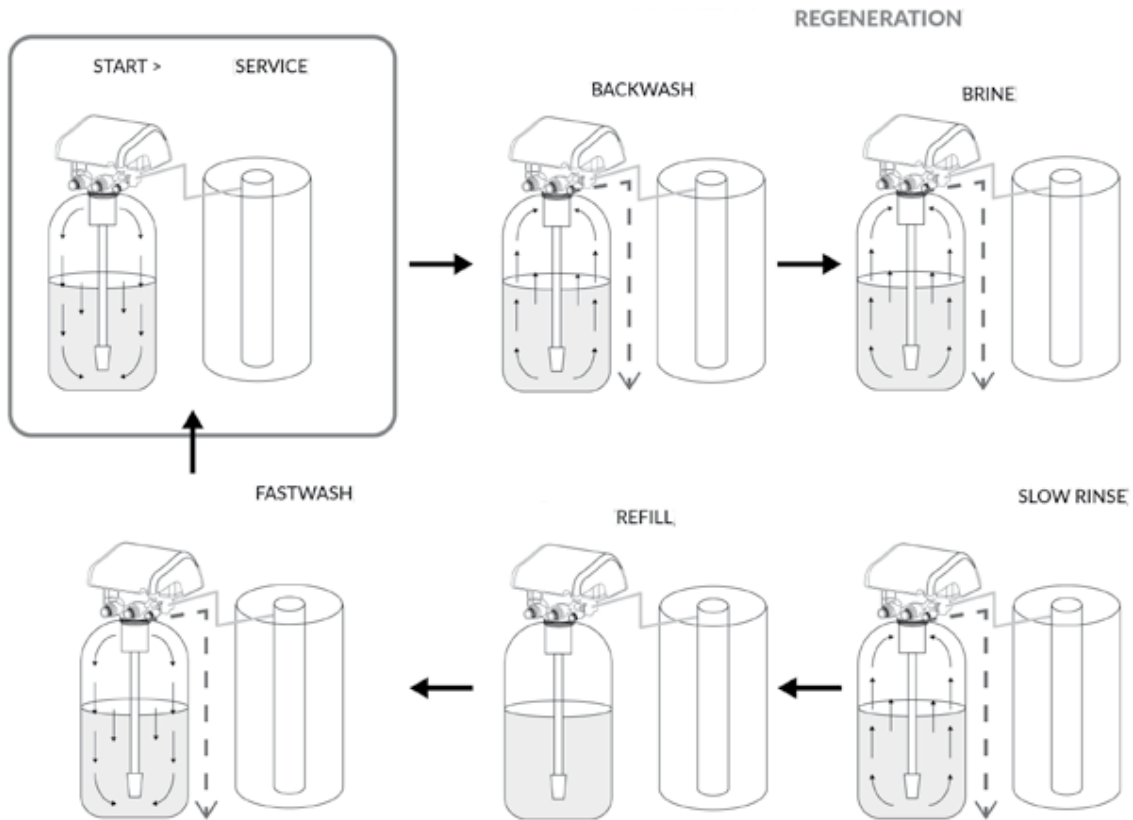

9. RX Control unit

The RX control unit is equipped with a microcomputer, with which the operating parameters of the water treatment system can be adapted to the physical-chemical parameters of the water.

The 79BD and 82BD controllers have two types of menus: open and closed.

To access an open menu, you must unlock the device by simultaneously pressing the "up-down" buttons.

In open menus you can edit the basic parameters, i.e. set the time and the water hardness, as well as determine the revitalisation time.

Switching between the parameters and changing the values is done by pressing the "up-down" buttons. The parameter selection and the confirmation of the changes are confirmed with "Enter".

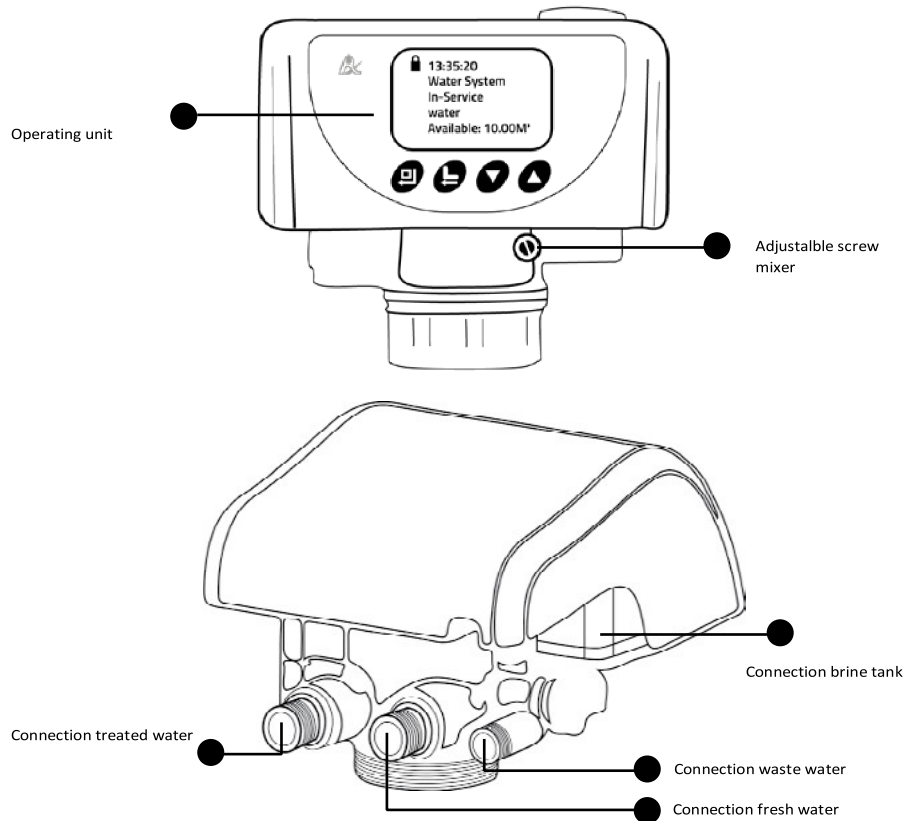

NOTE!! You must have the necessary knowledge to access the closed menu. Changing the operating parameters without proper knowledge may result in the unit consuming more water or salt, or the revitalisation process not working properly, or otherwise impairing the operation of the appliance.

10. Description of the control buttons

During water treatment, the screen shows the following:

In Operation - During revitalisation: The current operating mode number (see description below) and the current amount of water that the unit can process without revitalisation being required.

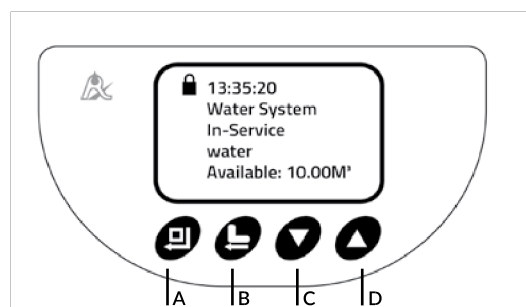

A-Menu / confirm; B- Force revitalisation / Back; C-down; D-up

11. Fill level control and salt refilling

11.1. Initial start-up

Before using the unit for the first time, pour salt into the salt container and fill with water. Wait about 30 minutes for enough salt to dissolve in the water. Then perform a revitalisation process.

11.2. Checking the Fill level and refilling with salt

You should check the amount of salt in the tank regularly (recommendation: at least once a week) to make sure there is enough salt. The table (see page 7) shows the average salt consumption for the revitalisation process. It should always be refilled with as much salt so that no more water is visible. Use only salt in tablet form intended for water treatment systems.

DANGER! Saltwater (brine) can cause eye, skin and wound irritation. Avoid contact with the inside of the brine tank. In case of contact with the saline solution, rinse with sufficient running water.

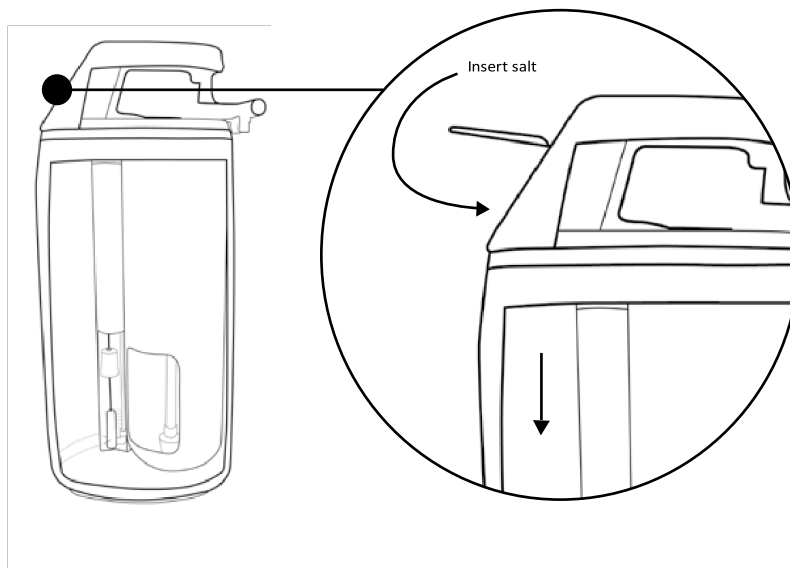

11.3. Prevention of clumping

High humidity or incorrect salt can lead to the formation of large salt deposits in the tank. These deposits can interfere with the proper revitalisation of the ion exchanger. As a result, the water is not properly processed.

If you suspect that salt deposits have formed, you can beat gently against the sides of the salt container (only with flat hands, never with tools). If this does not help, you can dissolve the deposits with warm water. Persistent clots can be broken open with a long screwdriver (CAUTION). If the clumps are due to poor salt, rinse the tank completely. Then fill the tank with salt, which is suitable for this type of water treatment system.

12. Problem detection

Problem	Reason	Solution
The device does not revitalise	No power	Check the power supply; power supply, plugs and fuses
	Control set incorrectly	Correct the settings in the device or ask a specialist to do so
The device delivers Hard water	Bypass open	Close the Bypass
	Lack of salt in brine tank	Refill salt and force revitalisation
	Dirty injector	Contact a specialist
	Insufficient water in brine tank	Check the regeneration time and initiate regeneration
	Eater mixer too far open	Change the settings in the control unit
	Revitalisation in progress	Wait for revitalisation to complete
Excessive salt consumption	Too much water in brine tank	Shorten the refill time
	Too much salt consumption	Shorten the refill time
Pressure drop	Deposits in the appliance	Clean the tank and hoses. Increase the revitalisation processes and / or increase the duration of the backwash.
	Clogging of pipes	Check whether the water supply to the system is provided.
	Input on the control unit dirty due to installation process.	Remove the dirt
	Polluted pre-filter	Clean or replace the pre-filter
	Air in the system	Check if there is enough brine in the tank before the regeneration starts
Too much water in the brine tank	Excessive dosing time of fresh water	Shorten the dosing time of the fresh water
	Blocked injector	Contact a specialist
	Foreign matter in brine tank	Change the content of the brine tank
	Interruptions when flushing into the brine tank	Check the power supply.
	Wrong setting for brine tank	Change the settings that affect brine tank

Brine is not drawn in.	Too low pressure	Increase the water pressure to at least 1,5 Bar
	Blocked hose between brine tank and control unit	Check and clean the hose
	Leaky hose between brine tank and control unit	Replace the hose with a new one
	Injector damaged	Contact a specialist
	Blockage in the sewer line	Check the drainage pipes
Constant drainage into the wastewater system	Impurities in the control unit	Check and clean the control unit and observe the behaviour at various stages of regeneration
	Power interruptions during regeneration	Check the power supply
The display shows E1-E1'	Damage to the electrical system or electronics	Contact a specialist
Purified water is salty	Rising process impaired	Check the pressure, drain lines and extend the rinse phase

13. Certificate

RX Controller are certified

1. CE - Conformity to EMV-Guidelines  2014/30/EU

14. Disposal

After expiry of the period of use, the device must no longer be disposed of as waste. Rather, the fixed water softener appliance should be brought to a collection point for electronic waste. The user is responsible for the proper disposal of the device. Failure to comply with the above rules may result in a penalty being imposed. Please observe the regulations applicable to your state. Proper disposal of the unit ensures proper waste treatment in an environmentally friendly manner.

15. TERMS OF WARRANTY

- The manufacturer warrants the smooth operation of the water softener if it has been operated according to the instructions in this manual and with regular refilling of the salt.
- The stationary water softener is guaranteed for 2 years from the date of purchase.
- The warranty is conditional on proper installation and commissioning of the device in accordance with the instructions by a qualified person.
- It is the responsibility of the user to have the device tested by an authorized person at least once a year.

- Operational damage or defects must be reported to the manufacturer no later than 14 days after occurrence.
- If our service technician determines that the defect reported by you does not exist, the service costs are to be borne by the user.
- The warranty is conditional to the installation being before the main line and systematic maintenance of the device.

The warranty does not apply to

- verification services;
- Device program modification services;
- Consumables consumed during use, such as filter cartridges or salt for regeneration;
- Damage caused by: Theft, fire, external influences or weather, by improper consumables, assembly of parts and components without the consent of the manufacturer;
- damage due to improper operation;
- Damage due to improper storage of the device and consumables
- consequences resulting from the decommissioning of the product;
- mechanical damage to the device

The buyer loses the warranty for the following reasons

- failure to follow the instructions in this manual;
- improper installation, commissioning and use of the device;
- failure to carry out the inspection by a specialist in due time;
- Unauthorized repairs, modifications and alterations by the buyer or third parties that do not comply with the instructions;
- mechanical damage to the device



Impress:



Adress:
BWI BestWater GmbH
Manager: Anita Gamon
Hermann-Löns-Straße 17
14547 Beelitz
GERMANY

Contact:
E-Mail: info@bestwater.de
Internet: www.BestWater.de
Online-Shop: www.Bwishop.de
Tel: +49 33204 62 86 0
Fax: +49 33204 62 86 11

HRB 26901 P
USt-IdNr: DE293844629